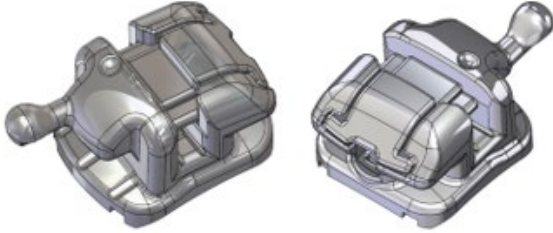

INSTRUCTIONS FOR USE

Pitts21 PRO™

1. Product Family & Part Numbers

Product Family	Product Part Numbers
Pitts21 PRO™ passive self-ligating bracket system. 	956.2XXX 256.2XXX 956.3XXX <i>XXX = Multiple bracket part numbers</i>
<i>Quick Turn Tool / Opening Instrument</i>	<i>246.1000</i>
<i>Debonding Instrument</i>	<i>533-0400</i>
<i>Archwire Seating Instrument</i>	<i>246.1002</i>

2. Description

The Pitts21 PRO™ metal orthodontic bracket system is a passive self-ligating bracket system for use in fixed appliance orthodontic treatment. The system consists of maxillary and mandibular brackets that are bonded directly to the clinical crown of the patient's teeth. The Pitts21 PRO™ brackets are sold non-sterile and designed for single use. Orthodontic adhesives and various hand instruments are required for bonding the Pitts21 PRO™ brackets to the patient's teeth. Other ancillary orthodontic products generally available to the orthodontic industry, such as archwires, elastics, power chain, and extension/compression springs, may be used with the Pitts21 PRO™ system to complement treatment. The Pitts21 PRO system is designed to use square finishing archwires with a nominal cross-section of 0.020" x 0.020". Follow the manufacturer's instructions for use for all ancillary orthodontic products used with the Pitts21 PRO™ bracket system.

3. Intended Use

The Pitts21 PRO™ bracket system is intended to be used in orthodontic treatment. The brackets are intended to be temporarily affixed to the teeth to transmit force to the teeth to create movement of teeth during treatment.

4. Indications for use

The Pitts21 PRO™ orthodontic metal bracket system is intended to aid in the movement of natural teeth in patients with malocclusion.

5. Contraindications

- Patient's inability or unwillingness to cooperate/or follow the treatment plan.
- Patient with deficient oral hygiene.
- Known allergies to any of the components or materials in the system.

- Any illness and/or underlying conditions that preclude orthodontic treatment.
- Any existing tooth root resorption.
- Any existing decalcification of the tooth enamel.

6. Materials

- Bracket Body & Ligating Member Table 1.

Table 1

Stainless Steel 17-4PH per ASTM B883 – 19		
Chemical Name	Min. (weight %)	Max. (weight %)
Iron (Fe)	Balance	Balance
Nickel (Ni)	3	5
Chromium (Cr)	15.5	17.5
Carbon (C)	-	0.07
Copper (Cu)	3	5
Silicon (Si)	-	1.0
Manganese (Mn)	-	1.0
Niobium; Tantalum (Nb+Ta)	0.15	0.45
Other	-	1.0

- Spring Member Table 2 & 3



Table 2

Nitinol per ASTM F2063		
Chemical Name	Min. (weight %)	Max. (weight %)
Titanium	Balance	Balance
Nickel	54.58	57
Carbon	-	0.04
Cobalt	-	0.05
Copper	-	0.01
Chromium	-	0.01
Hydrogen	-	0.005
Iron	-	0.05
Niobium	-	0.025
Nitrogen	-	0.005
Oxygen	-	0.04

Table 3

Coating “DLC (Diamond-Like Carbon)”

7. Warnings and Precautionary Measures

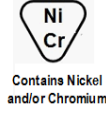
	<p>Federal law restricts this device to the sale by or on the order of a licensed orthodontist.</p>
	<p>The Pitts21 PRO™ system is designed for single use patient use only, by a professional or on the order of an orthodontist or a dentist.</p> <p>There is a risk of cross-contamination between patients if re-used.</p>
	<p>This product contains nitinol, an alloy of nickel and titanium, and should not be used for individuals with known allergic sensitivity to these metals. Prior to use, patients should be counseled on the materials contained in the device, as well as the potential for allergy/hypersensitivity to these materials.</p> <p>Do not use on patients with known allergies to any of the materials in the Pitts21 PRO™ system. Immediately remove the brackets in the event of an allergic reaction.</p>
<p>Devices are sold Non-Sterile</p>	
<p>MRI (Magnetic Resonance Imaging) Safety Information – The Pitts21 PRO™ bracket system has not been evaluated for safety and compatibility in the MR (Magnetic Resonance) environment. It has not been tested for heating, migration, or image artifact in the MR environment. The safety of the Pitts21PRO™ brackets in the MR environment is unknown. Scanning a patient who has this device may result in patient injury.</p>	
<p>Do not use any products which are damaged, or do not comply with the labeling specifications.</p>	
<p>Do not force any instrument into the bracket's archwire slot in either the open or closed condition as this may result in bracket damage.</p>	
<p>Ensure the bracket door is completely closed and the wire seated properly in the archwire slot. If the door is not completely closed/ligated, this may allow the wire to escape.</p>	
<p>Care should be taken to avoid contact with opposing teeth at occlusion.</p>	
<p>Follow all regional and national standards regarding the use of orthodontic appliances.</p>	
<p>If, in relation to the use of Pitts21 PRO™ bracket system, a death or serious deterioration of health has occurred, this should be reported to the manufacturer and the competent authority of your country.</p>	

8. Patient Information

- There is no information available which would preclude the use of commonly available oral healthcare products.
- Chewing hard foods can cause appliances to loosen or come off.
- Some sports may cause damage to orthodontic appliances, and their presence may increase the risk of harm in the event of certain sports-related injuries.
- When participating in sports, always wear appropriate mouth and/or bracket guards as recommended by the dental professional treating the patient.
- Always inform the MRI or radiology staff that braces are in place before any procedure to ensure appropriate measures are taken for the procedure.

9. General Information for the Dentist/Orthodontist

- As part of developing a treatment plan, and before appliance placement, assess the need for interdisciplinary coordination with other professionals, such as speech pathologists, otolaryngologists, physicians, dentists and/or orthodontists.
- Follow the manufacturer's instructions for any orthodontic bonding agents, instruments or other materials used in the orthodontic treatment.
- Orthodontic training in standard procedures will determine appropriate instruments for use during appliance placement and removal.
- Do not touch bonding surfaces with bare fingers, since skin oils may diminish the adhesion of orthodontic bonding materials.
- Oral hygiene is of particular importance for immunocompromised patients. Closely monitor oral hygiene on immunocompromised patients.
- Assess whether further orthodontic treatment is advisable in the presence of root resorption.
- Brackets should be removed per recommended de-bonding procedure.
- The Pitts21 PRO™ system is designed to use square finishing archwires with a "full-size nominal cross-section of 0.020" x 0.020".

10. Handling Procedure on how to use the medical device (Instructions for Use)

- **Bonding**
 - Use conventional orthodontic adhesive, following the manufacturer's instructions to bond the brackets to the patient's teeth
 - Color codes on the distal side and permanent identifications are provided to assist in bracket position identification.
 - After bonding remove color identification using a toothbrush.

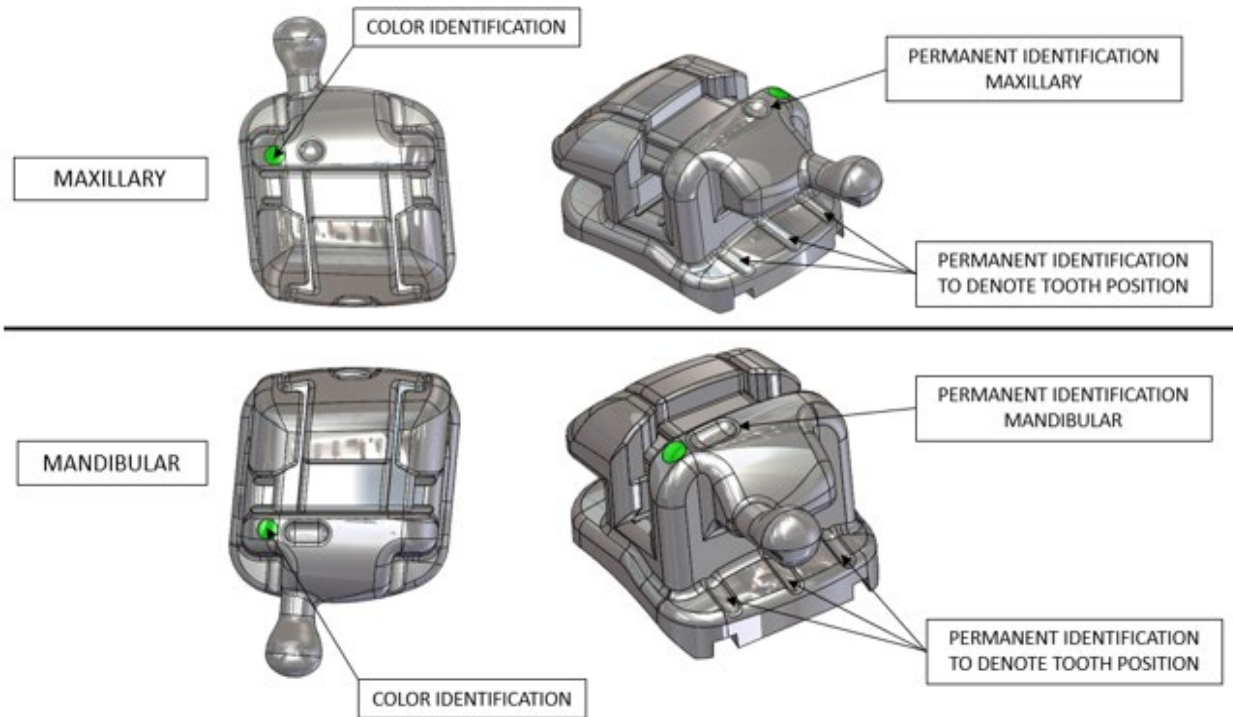

- Before the adhesive cures, use an appropriate dental instrument to remove excessive adhesive “flash” around the perimeter of the bracket base, at the bracket-tooth interface. It is particularly essential to remove the excess adhesive flash from the mesial-distal edges of the bracket base. The mesial-distal sides of the bracket base contain features to aid in debonding the bracket at the end of treatment. Excess adhesive flash could obstruct the debonding features if it is not removed.
- **Operating the Ligating Door**
 - To open the ligating door, insert the Quick Turn Tool (Opening Instrument), centering it in the recess on the labial surface of the ligating door. Align the Instrument perpendicular to the Wire Slot and rotate the Quick Turn Tool 90 degrees in either the clockwise or counterclockwise direction. Only a 90-degree rotation is required to fully open the ligating door. Rotating the Quick Turn Tool more than 90 degrees will NOT open the ligating door any further and will NOT cause any damage.
 - Once the archwire has been inserted into the archwire slot and fully seated into the archwire slot; push the occlusal edge of the ligating door using the tip of the opening instrument or a gloved fingertip to close the ligating door. It may be necessary to hold the archwire down into the slot with the recommended OC-Orthodontics Archwire Seating Instrument (P/N 246.1002) to ensure the archwire is fully seated before pushing the ligating door closed. Both an audible click and a light tactile snap will occur at the fully closed position.

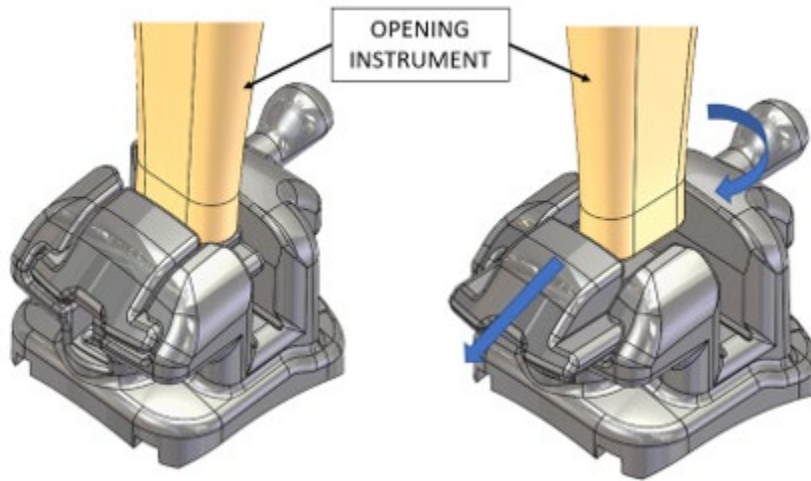

11. Recommended De-Bonding Procedure

Different de-bonding procedures are acceptable to de-bond the Pitts21 PRO™ bracket from the patient's tooth. It is recommended, that the archwire remains ligated in the Pitts21 PRO™ brackets to maintain control of the brackets when they are de-bonded from the tooth. The recommended de-bonding instrument is the OC-Orthodontics de-bonding instrument (P/N 533-0400)

a. De-Bonding Procedure #1

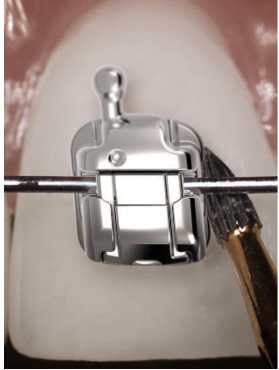
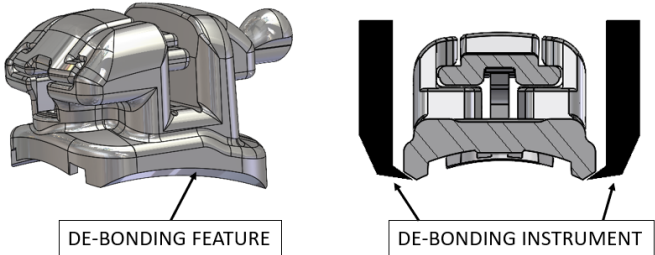
<p>Remove excess adhesive flash from the mesial and distal sides of the bracket with a Flame Carbide Bur or equivalent.</p>	
<p>Locate the wedge shape tips of the debonding instrument into the angled debonding feature located on the mesial and distal sides of the bracket. The notches in the wedged tips of the OC Orthodontics debonding instrument are designed to straddle the archwire.</p>	

Squeeze the handles of the debonding plier together to wedge the tips of the debonding plier into the debonding features on the mesial and distal sides of the bracket base. While squeezing the handles together pivot the handles either in the mesial or distal direction to de-bond the bracket from the tooth.

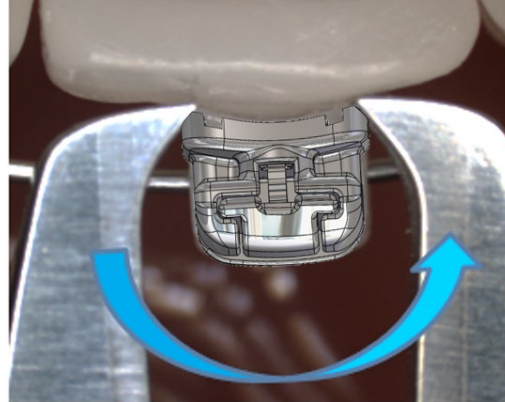

Remove any adhesive residue remaining on the tooth surface with an appropriate adhesive removing instrument.

b. De-Bonding Procedure #2

Locate the plier tips of the debonding instrument underneath the occlusal-gingival tie wings. While squeezing the handles together pivot the plier from the gingival to the occlusal direction to de-bond the bracket.

Applying lingual support with a gloved finger during debonding might be beneficial for patient comfort.

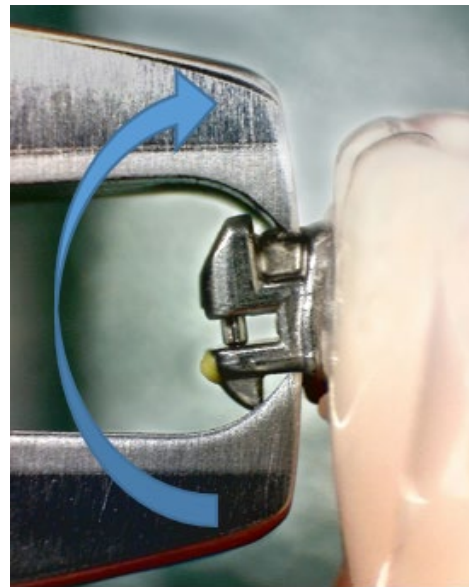

Remove any adhesive residue remaining on the tooth surface with an appropriate adhesive removing instrument.

12. Cleaning and sterilization instructions

- The device is provided nonsterile, nor is it intended to be sterilized by the user. The industry standard of care for orthodontic devices is that the devices are provided to the orthodontist in protective packaging, they are removed from the packaging for use on the patient and the devices are not handled nor sterilized before their use.
- There is no information available that would preclude the use of commonly available oral healthcare products like toothbrushes, toothpaste, water pick, mouth wash, etc.

13. Disposal (if applicable)

- Disposal of all orthodontic appliances must follow regional and national regulations.

14. Storage and Handling for medical devices (if applicable)

- The device should be stored in a dry environment under ambient conditions.

15. Name and address of labeler

	World Class Technology 1300 NE Alpha Dr. McMinnville, OR 97128 USA
---	--

16. Name, address, and number of Notified Body





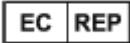

	TUV Rheinland LGA Products GmbH Tillystrasse 2, 90431 Nurnberg, Germany +49 221 808-1371 Notified Body No.: 0197
---	--



17. Name, address, and number of Authorized Representative

	MDI Europa Langenhagener STR.71 30855 Langenhagen, Germany +49-511-3908-9530 SRN: DE-AR-000006218
---	--

18. Explanation of Symbols

The following are per ISO 15223-1 (References as indicated).

Symbol Standard Reference	SYMBOL TITLE – Explanatory Text
 Ref. 5.1.1	Manufacturer: Indicates the medical device manufacturer.
 Ref. 5.1.5	Batch Code: Indicates the manufacturer's batch code so that the batch or lot can be identified.
 Ref. 5.1.6	Catalogue or model number: Indicates the manufacturer's catalogue number so that the medical device can be identified.
 Ref. 5.2.7	Non-sterile: Indicates a medical device that has not been subjected to a sterilization process.
 Single Use Ref. 5.4.2	Do not re-use/single patient use: Indicates a medical device that is intended for one use, or for use on a single patient during a single procedure.
 Ref. 5.4.3	Consult instructions for use: Indicates the need for the user to consult the instructions for use.
 Ref. 5.7.7 MDR 2017/745 Annex 1 23.2(q)	Medical Device: Indicates that the device is a medical device.

Symbols Not Derived from Standards	
 21 CFR 801.109	Prescription Only: CAUTION: U.S. Federal law restricts this device for sale by or on order of a licensed dentist or physician.
 Contains Nickel and/or Chromium	Product contains Nickel and/or Chromium FDA 21 Part 872 Sec. 872.3710 Base metal alloy.